



2903

Test Cell for Liquid Insulants



GENERAL

The precision test cell type 2903 measures the dielectric properties of liquid insulants such as insulating oil, i.e. it determines the dissipation factor $\tan \delta$ and the dielectric constant ϵ_r as well as the specific resistivity.

The test cell has been designed as a cylindrical capacitor with a shielded measuring electrode (guard ring capacitor) thus avoiding partial capacitances, which might influence the test results.

The test cell's design is in accordance with the specifications of VDE 0303, 0370 (Fed. Republic of Germany), SEV (Switzerland) and the recommendations of CIGRE, IEC and ISO, as well as with ASTM standards (USA).

The temperature controller type 2967 with digital temperature adjustment is used to heat up the test cell.

ADVANTAGES & BENEFITS

- The test cell is in accordance with international standards and specifications.
- The test cell is heatable.
- The temperature is adjustable up to 150°C
- The cell can be evacuated, e.g. to degas the insulating oil.
- The electrodes are made of stainless steel.
- The test results are reproducible thanks to precise mechanical design.

DESIGN FEATURES

The complete test cell type 2903 consists of the actual test cell type 2903a as well as a pot with built-in heating.

The test cell consists of a cylindrical container (high-voltage electrode) with a shielded measuring electrode inside. The cell is vacuum-sealed by a locking head. It further includes a socket for the measuring electrode, two vacuum connections, and a stern thermometer.

To conduct measurements the test cell is inserted into the pot. The sockets for high voltage, the temperature controller and the temperature measuring bridge are mounted on the pot's top panel made of insulation material. Always check suitability of the equipment for the considered test cells. It should also be noted that the power supply used must have a low short-circuit power characteristic (e.g. a resonant power supply).

To degas the measured liquid (e.g. oil) we recommend our vacuum pump type 2973.

TECHNICAL SPECIFICATIONS

No-load capacitance	≈ 60 pF
Electrode spacing	2 mm
Amount of liquid	40 cm ³
Electrode material	stainless steel
Surface	micro finished
Electrode temperature	ambient temperature .. 150°C
Heating capacity	heating jacket 300 W, heating cartridge 150 W, total 450W
Heat-up time	60 min.
Built-in fuses	4 A
Max. test voltage	2000 V RMS, 50/60 Hz
Max. electric field	10 kV/cm
Dimensions	0 95x175 mm (3.8x6.9 ins) Test cell type 2903a 0 240x220 mm (9.5x8.7 ins) Test cell 2903a with heating pot 2903
Weight	5.2 kg (11.5 lbs) Test cell type 2903a 8.2 kg (18 lbs) Test cell with heating type 2903

TECHNICAL SPECIFICATION OF TEST CELL

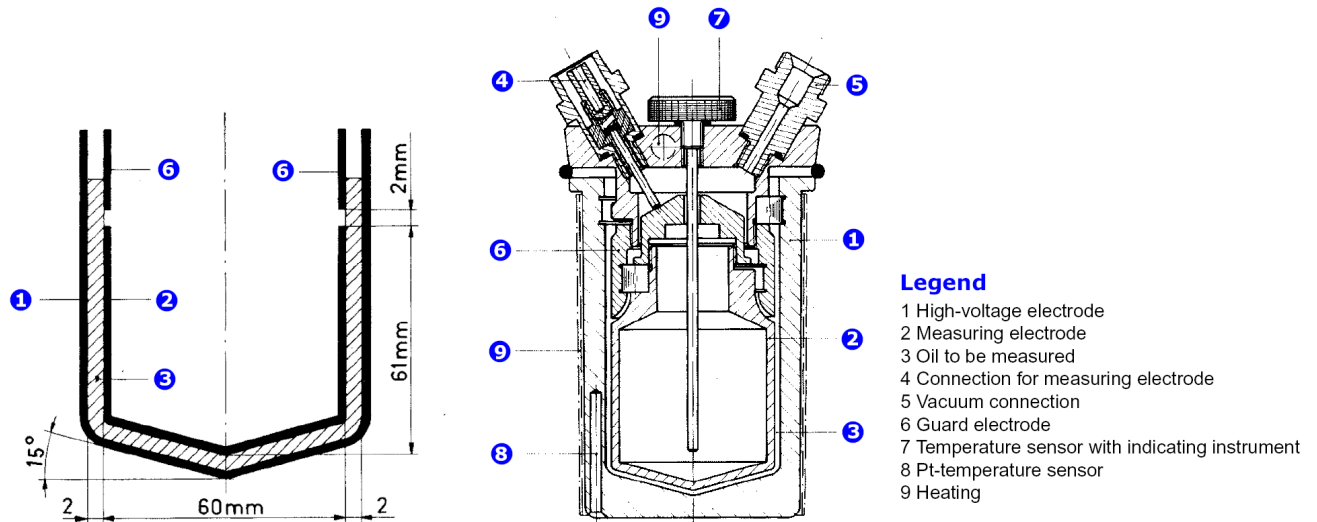

SCOPE OF SUPPLY

- Heated test cell for liquid insulation type 2903
- Heating voltage: 230 V or 115 V 50/60 Hz (need only be quoted when temperature controller type 2967 is used)
- Tools and spares
- Vacuum pump hose coupling
- Two connecting cables to measuring bridge and power supply

OPTIONAL

- 2967: Temperature controller, control range up to 300°C
- 2973: Vacuum pump equipment



Test cell 2903a



Heating pot 2903

European Contact

Haefely Test AG
Lehenmattstrasse 353
4052 Basel
Switzerland
☎ + 41 61 373 4111
☎ + 41 61 373 4912
✉ sales@haefely.com

Locate your local sales representative at

www.haefely.com

USA Contact

Hipotronics Inc.
1650 Route 22
PO Box 414
Brewster, NY 10509 USA
☎ + 1 845 279 8091
☎ + 1 845 279 2467
✉ sales@hipotronics.com

a brand of

HAEFELY 

precision.
swiss made.

Haefely is a subsidiary
of Hubbell Incorporated.

